

Rear Clevis Mountings, Slim Clevis

Materials:

Mounting: Aluminium.
Screws: Steel, zinc-plated.
Bolts: Stainless Steel.

Mounting element at the end cover.

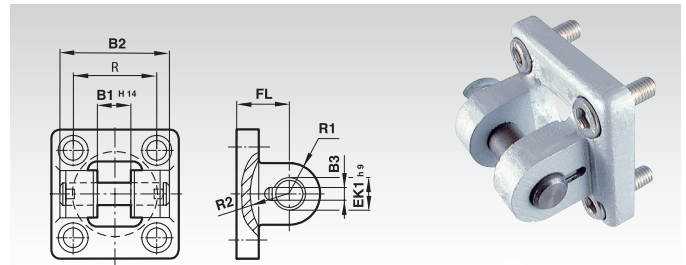

Ordering Details: e.g.: Product No. 810 008 32, Rear Clevis Mounting for Cylinder Ø 32 mm

Product No.	Cyl. Ø mm	B1 ^{H14} mm	B2 mm	B3 mm	EK1 ^{h9} mm	FL mm	R mm	R1 mm	R2 mm	Weight g
810 008 32	32	14	34	3,3	10	22	32,5	11	17	150
810 008 40	40	16	40	4,3	12	25	38	12	20	250
810 008 50	50	21	45	4,3	16	27	46,5	14,5	22	400
810 008 63	63	21	51	4,3	16	32	56,5	18	25	550
810 008 80	80	25	65	4,3	20	36	72	22	30	900

Bracket Hinge Mountings with Spherical Bearing (Steel) for Slim Clevis

Materials:

Bracket hinge: Grey cast iron, coated.
Inner ring: Roller bearing steel, hardened.
Outer ring: Steel.

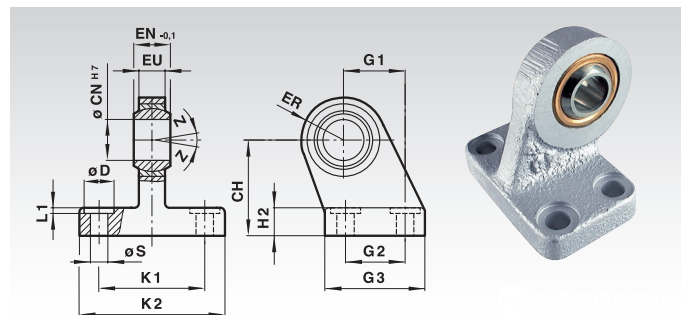

Ordering Details: e.g.: Product No. 810 011 32, Bracket Hinge Mounting, with Spherical Bearing, for Cylinder Ø 32 mm

Product No.	Cyl. Ø mm	CH mm	CN ^{H7} mm	Ø D mm	EN ^{-0.1} mm	ER mm	EU mm	G1 mm	G2 mm	G3 mm	H2 mm	K1 mm	K2 mm	L1 mm	Ø S mm	Z Degrees	Weight g
810 011 32	32	32	10	11	14	16	10,5	21	18	31	8	38	51	1,6	6,6	13°	190
810 011 40	40	36	12	11	16	18	12	24	22	35	10	41	54	1,6	6,6	13°	240
810 011 50	50	45	16	15	21	21	15	33	30	45	12	50	65	1,6	9	13°	460
810 011 63	63	50	16	15	21	23	15	37	35	50	12	52	67	1,6	9	15°	590
810 011 80	80	63	20	18	25	28	18	47	40	60	14	66	86	2,5	11	15°	1030

Trunnion Mountings (front or rear)

Materials:

Mounting: Grey cast iron.
Screws: Steel, zinc-plated.

Mounting element at the bearing or end cover.

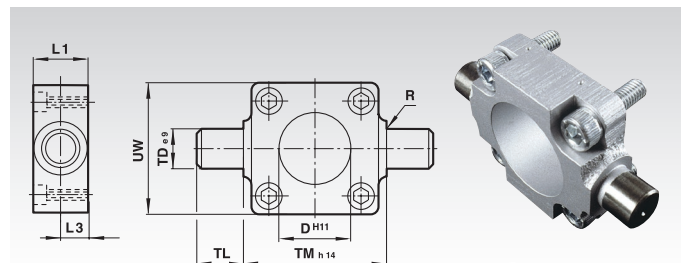

Ordering Details: e.g.: Product No. 810 013 32, Trunnion Mounting for Cylinder Ø 32 mm

Product No.	Cyl. Ø mm	ØD ^{H11} mm	L1 mm	L3 mm	R mm	ØTD ^{e9} mm	TL mm	TM ^{h14} mm	UW1 mm	Weight g
810 013 32	32	30	16	8	1,0	12	12	50	50	200
810 013 40	40	35	20	10	1,6	16	16	63	55	380
810 013 50	50	40	24	12	1,6	16	16	75	65	600
810 013 63	63	45	24	12	1,6	20	20	90	75	1100
810 013 80	80	45	28	14	1,6	20	20	110	100	1900