

Double-Acting Compact Cylinder with Magnetic Piston, According to ISO 21287

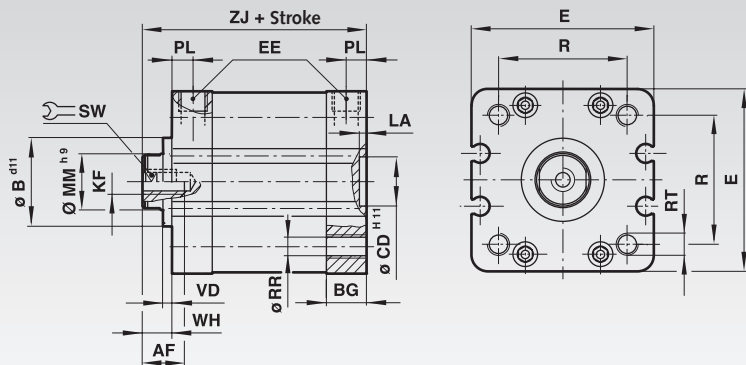

Materials:

Profile barrel: Anodised aluminium.
 End covers: Aluminium die-cast.
 Piston rod: Stainless steel (Ø 20 and 25 mm austenitic, Ø 32 and 40 mm ferritic).
 Piston rod seal: Polyurethane.
 Piston seal: Nitrile rubber.
 O-ring seals: Nitrile rubber.

Medium: Compressed air, filtered, lubricated or non-lubricated
 Standard: ISO 21287.

Mode of operation: double-acting, magnetic piston, piston rod with internal thread, buffer cushioning.

Operating pressure: 1 to 10 bar.

Operating temperature: -5°C* to +80°C.

* With temperatures below +2°C please consider the air quality.

On request also available with external thread.

Ordering details: e.g.: Product No. 803 200 10, Double-Acting Compact Cylinders with Magnetic Piston, Cylinder Ø 20 mm, Stroke 10 mm

Cylinder Ø mm	Theoretical Forces at 6 bar (N)	
	Thrust	Pull
20	188	141
25	294	247
32	482	414
40	754	633

Symbol

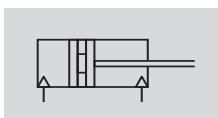

Product No.	Standard Strokes			Cyl. Ø mm	Connection
	10 mm	25 mm	50 mm		
803 200 10	803 200 25	803 200 50	20	M5	
803 250 10	803 250 25	803 250 50	25	M5	
803 320 10	803 320 25	803 320 50	32	G1/8	
803 400 10	803 400 25	803 400 50	40	G1/8	

Cyl. Ø mm	AF mm	BG mm	Ø CD ^{H11} mm	E mm	EE	KF	LA mm	Ø MM ^{h9} mm
20	10	12	10	37	M 5	M 6	2,5	10
25	10	13	10	41	M 5	M 6	2,5	10
32	12	14,5	14	48	G 1/8	M 8	2,5	12
40	12	14,5	14	54,4	G 1/8	M 8	2,5	16

Cyl. Ø mm	PL mm	R mm	Ø RR mm	RT mm	SW mm	WH mm	ZJ mm	Weight in kg	
								at 0 mm	per 5 mm
20	7	22	4,3	M 5	8	6	43	0,12	0,01
25	7	26	4,3	M 5	8	6	45	0,15	0,01
32	7,5	32,5	5,3	M 6	10	7	51	0,23	0,02
40	7,5	38	5,3	M 6	13	7	52	0,30	0,02

Mounting Elements for Compact Cylinders

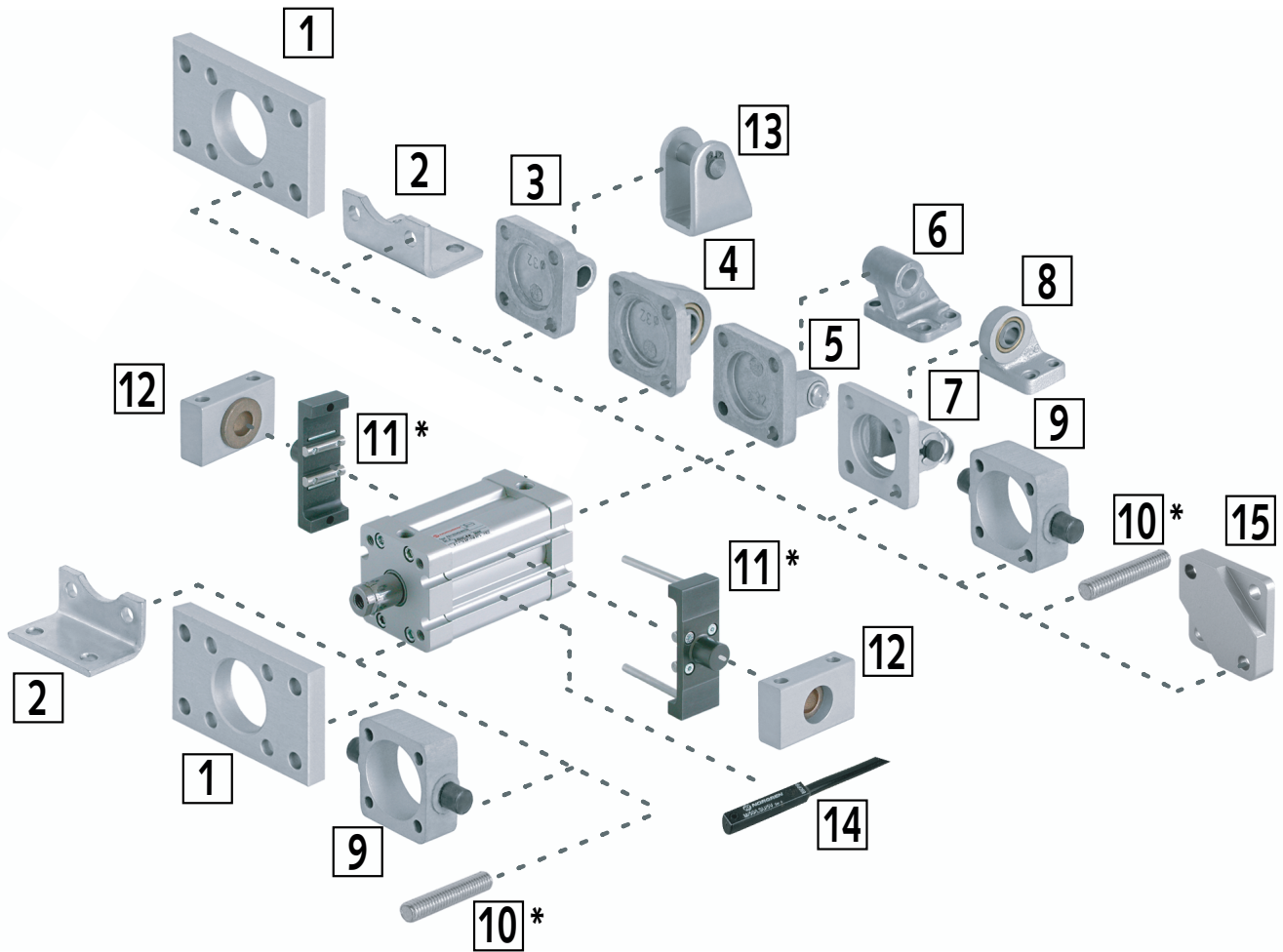

No. Designation	Cylinder Ø 20mm Product No.	Cylinder Ø 25mm Product No.	Cylinder Ø 32mm Product No.	Cylinder Ø 40mm Product No.	Dim. Page
1 Rear Flange, Front Flange	810 001 20	—	810 001 32	810 001 40	816
2 Foot Plate Mounting	810 002 20	810 002 25	810 002 32	810 002 40	816
3 Rear Eye Mounting	810 004 20	810 004 25	810 004 32	810 004 40	816
4 Rear Eye Mounting with Spherical Bearing	—	—	810 012 32	810 012 40	817
5 Rear Clevis Mounting, Wide	—	—	810 007 32	810 007 40	817
6 Bracket Hinge Mounting, Rigid, Wide for No. 5	—	—	810 010 32	810 010 40	817
7 Rear Clevis Mounting Slim	—	—	810 008 32	810 008 40	818
8 Bracket Hinge Mounting with Spherical Bearing No.7	—	—	810 011 32	810 011 40	818
9 Trunnion Mounting	—	—	810 013 32	810 013 40	818
10 Front or Rear Stud Mounting *	—	—	810 006 32*	810 006 32*	-
11 Adjustable Trunnion Mounting *	—	—	810 014 32*	810 014 40*	-
12 Swivel Bearing Sets for No.9 oder No.11	—	—	810 015 32	810 015 40	819
13 Bracket Hinge Mounting	810 023 20	810 023 20	—	—	822

* Discontinued item.

No. 14: Magnetic switches 810 000 01 to 810 000 07 (page 823) can be mounted straight on the keyways of the profile barrel, without further elements.