

Sliding Hubs with Torsionally-Flexible Coupling RNR

Material: Sliding hub: steel, zinc-plated and chromated, rust-proof friction pads.

Elastic coupling: coupling hub steel (size 00 from aluminium), spider (plastic insert) Polyurethane. Hardness 92° Shore A (optional 98° Shore A).

- The slipping torque can be adjusted with common assembly tools for screws.
- The elastic coupling can be mounted in axial direction.
- Torque can be altered after mounting.
- By mounting additional springs, the torque range can be increased. (additional springs have to be ordered separately).
- Customized bores and feather-key grooves available at extra charge.

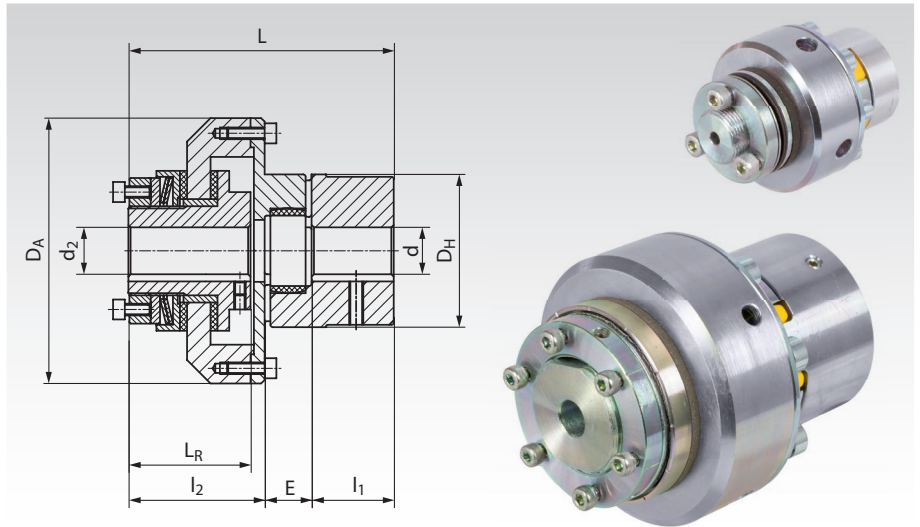

Ordering Details: e.g.: Product No. 612 199 00, Sliding Hub RNR with Torsionally-Flexible Coupling

Product No.	Size	d ; d ₂	d _{max.} mm	d _{2 max.} mm	D _A mm	D _H mm	l ₁ mm	E mm	l ₂ mm	L _R mm	L mm	Weight kg
612 199 00	00	4,8	16	10	44	30	11	13	35	31	59	0,35
612 200 00	0	5,7	25	20	63	40	25	16	37	33	78	0,90
612 201 00	01	10	35	22	80	55	30	18	50	45	98	1,95
612 202 00	1	10	40	25	98	65	35	20	58	52	113	3,10
612 203 00	2	14	48	35	120	80	45	24	64	57	133	5,50

Size	Torque of Sliding Hub			Torque Coupling T _{KN} ³⁾ Nm	Torque Coupling T _{Kmax.} ⁴⁾ Nm	Speed max. min ⁻¹
	Standard ¹⁾ Nm	Optional ²⁾ Nm	Optional ²⁾ Nm			
00	0,5 - 5	1 - 10	-	7,5	15	10.000
0	2,0 - 10	4 - 20	-	10,0	20	8.500
01	5,0 - 35	10 - 70	60 - 105	35,0	70	6.600
1	20,0 - 75	40 - 150	130 - 200	95,0	190	5.600
2	25,0 - 140	50 - 280	250 - 400	190,0	380	4.300

¹⁾ With one disc spring (standard version).

²⁾ With second or third disc spring (order separately).

³⁾ Nominal torque of the elastic coupling with standard spider 92° Shore A.

⁴⁾ Maximum torque of the elastic coupling with standard spider 92° Shore A.

Replacement Friction Discs and additional Disc Springs

Matching Coupling Product No.	Size	Outer			Outer		
		Product No. Friction Disc ¹⁾	Ø mm	Weight g	Product No. Disc Spring	Ø mm	Weight g
612 199 00	00	612 100 01	30	2	612 100 02	30	5
612 200 00	0	612 100 11	45	3	612 100 12	42,5	5
612 201 00	01	612 101 01	58	10	612 101 02	53,1	10
612 202 00	1	612 101 11	68	13	612 101 12	61,5	20
612 203 00	2	612 102 01	88	21	612 102 02	79,5	40

¹⁾ 2 pieces required.

Spiders for RNR

Matching Coupling Product No.	Size	Product No. Spare Part Spider 92° Shore, yellow	Torque		Product No. Optional Spider 98° Shore, red	Torque		Weight g
			Nom. Nm	max. Nm		Nom. Nm	max. Nm	
612 199 00	00 (14)	605 092 14	7,5	15	605 098 14	12,5	25	5
612 200 00	0 (19)	605 092 19	10	20	605 098 19	17	34	7
612 201 00	01 (24)	605 092 24	35	70	605 098 24	60	120	22
612 202 00	1 (28)	605 092 28	95	190	605 098 28	160	320	32
612 203 00	2 (38)	605 092 38	190	380	605 098 38	325	650	58

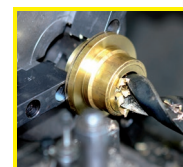

Reworking within 24h-service possible. Custom made parts on request.